

# 2-Circuit Axial Piston Variable Pump A30VG

**RE 93430/06.09** 1/20  
Replaces: 04.08

## Data sheet

Series 10  
Size NG28  
Nominal pressure 300 bar  
Maximum pressure 350 bar  
Closed circuit



## Contents

Ordering code for standard program	2
Technical data	4
HW – Proportional control hydraulic, mechanical servo	9
EP – Proportional control electric	10
Connector for solenoids	11
DA control valve	11
Dimensions size 28	12
Through drive dimensions	14
Overview of attachments	15
High-pressure relief valves	16
Installation situation for coupling assembly	16
Mechanical stroke limiter	17
Ports X <sub>3</sub> and X <sub>4</sub> for stroking chamber pressure	17
Filtration boost circuit / external supply	18
Installation instructions	19
General instructions	20

## Features

- Compact 2-circuit variable pump of swashplate design for hydrostatic drives in closed circuit
- Two equal flows from one pump to supply two separate circuits
- All functions needed to achieve a differential lock effect are integrated in the pump.
- The flow increases as the angle of the swashplate is adjusted from zero to its maximum value.
- A wide range of highly adaptable control devices with different control and regulating functions, for all important applications.
- Single control for both circuits
- Two pressure-relief valves are provided on the high pressure ports to protect the hydrostatic transmission (pump and motor) from overload.
- The high-pressure relief valves also function as boost valves.
- The integrated boost pump acts as a feed pump and control pressure supply.
- The maximum boost pressure is limited by a built-in boost pressure-relief valve.
- All types of hydraulic motor can be used as drive units
- Short, compact design makes installation and wiring easier in tight spaces

# Ordering code for standard program

<b>A30V</b>	<b>G</b>	<b>028</b>			<b>0</b>			/	<b>10</b>	<b>M</b>		-	<b>N</b>	<b>C2</b>		<b>1</b>					
01	02	03	04	05	06	07	08		09	10	11		12	13	14	15	16	17	18	19	20

## Axial piston unit

01	Swashplate design, variable, nominal pressure 300 bar, maximum pressure 350 bar															<b>A30V</b>
----	---	--	--	--	--	--	--	--	--	--	--	--	--	--	--	-------------

## Operation mode

02	Pump, closed circuit															<b>G</b>
----	----------------------	--	--	--	--	--	--	--	--	--	--	--	--	--	--	----------

## Size

03	Displacement $V_{g\max}$ in $\text{cm}^3$															<b>028</b>
----	---	--	--	--	--	--	--	--	--	--	--	--	--	--	--	------------

## Control device

028

04	Proportional control hydraulic	mechanical servo, hexagon shaft with lever	●	<b>HW1</b>
	Proportional control electric, with supply filtration	$U = 12 \text{ V DC}$	●	<b>EP3</b>
		$U = 24 \text{ V DC}$	●	<b>EP4</b>

## Connector for solenoids<sup>1)</sup>

05	Without															<b>0</b>
	DEUTSCH - molded connector, 2-pin – without suppressor diode															<b>P</b>

## Auxiliary function 1

06	Without															<b>0</b>
----	---------	--	--	--	--	--	--	--	--	--	--	--	--	--	--	----------

## Auxiliary function 2

07	Without															<b>0</b>
	With mechanical stroke limiter, externally adjustable															<b>M</b>
	With ports $X_3$ , $X_4$ for stroking chamber pressure															<b>T</b>
	With mechanical stroke limiter and ports $X_3$ , $X_4$															<b>B</b>

## DA control valve

HW EP

08	Without															●	●	<b>0</b>
	With DA control valve, fixed setting															○	○	<b>1</b>

## Series

09	Series 1, Index 0															<b>10</b>
----	-------------------	--	--	--	--	--	--	--	--	--	--	--	--	--	--	-----------

## Version of port and fixing threads

10	Metric															<b>M</b>
----	--------	--	--	--	--	--	--	--	--	--	--	--	--	--	--	----------

## Direction of rotation

11	Viewed from drive shaft															$\text{clockwise}$		<b>R</b>
																$\text{counter-clockwise}$		<b>L</b>

## Seals

12	NBR (nitrile-caoutchouc), shaft seal ring in FKM (fluor-caoutchouc)															<b>N</b>
----	---	--	--	--	--	--	--	--	--	--	--	--	--	--	--	----------

## Mounting flange

13	SAE J744										127-2 (C)					<b>C2</b>
----	----------	--	--	--	--	--	--	--	--	--	-----------	--	--	--	--	-----------

● = Available      ○ = On request

1) Connectors for other electric components can deviate.

# Ordering code for standard program

<b>A30V</b>	<b>G</b>	<b>028</b>							/	<b>10</b>	<b>M</b>		-	<b>N</b>	<b>C2</b>		<b>1</b>					
01	02	03	04	05	06	07	08			09	10	11		12	13	14	15	16	17	18	19	20

## Drive shaft

14	Splined shaft ANSI B92.1a-1976	1 1/4 in 14T 12/24DP	<b>S7</b>
		1 3/8 in 21T 16/32DP	<b>V8</b>

## Service line ports

15	Circuit 1: double SAE flange port, left; Circuit 2: single SAE flange port at top and bottom; suction port at bottom (viewed from drive shaft)	<b>1</b>
----	---	----------

## Boost pump

16	With integrated boost pump (standard)	<b>F</b>
	Without integrated boost pump (no pressure filtration possible)	<b>U</b>

## Through drive

	Flange SAE J744			Coupling for splined shaft <sup>2)</sup>			
	Diameter	Mounting variant		Diameter	Designation		
		Symbol	Designation				
17	Without						<b>0000</b>
	82-2 (A)	∞	A1	5/8 in 9T	16/32DP	S2	<b>A1S2</b>
			A2	5/8 in 9T	16/32DP	S2	<b>A2S2</b>
	101-2 (B)	∞	B1	7/8 in 13T	16/32DP	S4	<b>B1S4</b>
				1 in 15T	16/32DP	S5	<b>B1S5</b>
			B2	7/8 in 13T	16/32DP	S4	<b>B2S4</b>
		1 in 15T		16/32DP	S5	<b>B2S5</b>	
	127-2 (C)	∞	C2	1 1/4 in 14T	12/24DP	S7	<b>C2S7</b>

## High-pressure valves

18	With high-pressure relief valve, direct controlled	without bypass	<b>3</b>
		with bypass	<b>5</b>

## Filtration boost circuit / external supply

19	Filtration in the boost pump suction line	<b>S</b>
	Filtration in the boost pump pressure line: Ports for external boost circuit filtration (F <sub>e</sub> and F <sub>a</sub> )	<b>D</b>
	External supply (on version without integrated boost pump)	<b>E</b>

## Standard / special version

20	Standard version		<b>-O</b>
		combined with attachment part or attachment pump	<b>-K</b>
	Special version		<b>-S</b>
		combined with attachment part or attachment pump	<b>-T</b>

### Note

Short designation X refers to a special version not covered by the ordering code.

● = Available      ○ = On request

2) Coupling for splined shaft acc. to ANSI B92.1a-1976

# Technical data

## Hydraulic fluid

Before starting project planning, please refer to our data sheets RE 90220 (mineral oil) and RE 90221 (environmentally acceptable hydraulic fluids) for detailed information regarding the choice of hydraulic fluid and application conditions.

The variable pump A30VG is not suitable for operation with HFA, HFB and HFC. If HFD or environmentally acceptable hydraulic fluids are being used, the limitations regarding technical data and seals must be observed.

Please contact us.

When ordering, indicate the hydraulic fluid that is to be used.

## Selection diagram

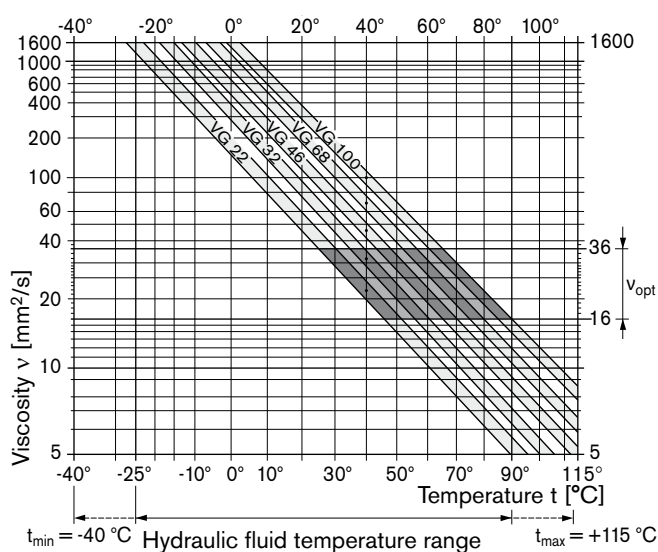

## Details regarding the choice of hydraulic fluid

The correct choice of hydraulic fluid requires knowledge of the operating temperature in relation to the ambient temperature: in a closed circuit the circuit temperature.

The hydraulic fluid should be chosen so that the operating viscosity in the operating temperature range is within the optimum range ( $\nu_{opt}$ ), see shaded area of the selection diagram. We recommended that the higher viscosity class be selected in each case.

Example: At an ambient temperature of X °C, an operating temperature of 60 °C is set in the circuit. In the optimum operating viscosity range ( $\nu_{opt}$ , shaded area), this corresponds to the viscosity classes VG 46 or VG 68; to be selected: VG 68.

## Note

The case drain temperature, which is affected by pressure and speed, is always higher than the circuit temperature. At no point of the component may the temperature be higher than 115 °C, however. The temperature difference specified below is to be taken into account when determining the viscosity in the bearing.

If the above conditions cannot be maintained due to extreme operating parameters, please contact us.

## Viscosity and temperature

	Viscosity [mm <sup>2</sup> /s]	Temperature	Comment
Storage		$T_{min} \geq -50$ °C $T_{opt} = +5$ °C to $+20$ °C	up to 12 months with standard factory conservation up to 24 months with long-term factory conservation
(Cold) start-up <sup>1)</sup>	$\nu_{max} = 1600$	$T_{St} \geq -40$ °C	$t \leq 3$ min, without load ( $p \leq 50$ bar), $n \leq 1000$ rpm
Permissible temperature difference		$\Delta T \leq 25$ K	between axial piston unit and hydraulic fluid
Warm-up phase	$\nu < 1600$ to 400	$T = -40$ °C to $-25$ °C	at $p_{nom}$ , $0.5 \cdot n_{nom}$ and $t \leq 15$ min
Operating phase			
Temperature difference		$\Delta T =$ approx. 5 K	The temperature of the hydraulic fluid in the bearing is (depending on pressure and speed) approx. 5 K higher than that of the case drain fluid at port T.
Continuous operation	$\nu = 400$ to 10 $\nu_{opt} = 16$ to 36	$T = -25$ °C to $+90$ °C	no restriction within the permissible data
Short-term operation	$\nu_{min} = < 10$ to 5	$T_{max} = +115$ °C	$t < 3$ min, $p < 0.3 \cdot p_{nom}$
Shaft seal ring FKM <sup>1)</sup>		$T \leq +115$ °C	See page 5

<sup>1)</sup> At temperatures below  $-25$  °C, an NBR shaft seal ring is required (permissible temperature range:  $-40$  °C to  $+90$  °C).

## Technical data

### Filtration of the hydraulic fluid

Filtration improves the cleanliness level of the hydraulic fluid, which, in turn, increases the service life of the axial piston unit.

To ensure the functional reliability of the axial piston unit, a gravimetric evaluation is necessary for the hydraulic fluid to determine the amount of contamination by solid matter and to determine the cleanliness level according to ISO 4406. A cleanliness level of at least 20/18/15 is to be maintained.

Depending on the system and the application, for the A30VG, we recommend

Filter cartridges  $\beta_{20} \geq 100$ .

With an increasing differential pressure at the filter cartridges, the  $\beta$ -value must not deteriorate.

At very high hydraulic fluid temperatures (90 °C to maximum 115 °C), a cleanliness level of at least 19/17/14 according to ISO 4406 is necessary.

If the above classes cannot be achieved, please contact us. For notes on filtration types, see page 18.

### Shaft seal ring

#### Permissible pressure loading

The service life of the shaft seal ring is affected by the speed of the pump and the case drain pressure. It is recommended that the average, continuous case drain pressure 3 bar absolute at operating temperature not be exceeded (maximum permissible case drain pressure 6 bar absolute at reduced speed, see diagram). Short-term ( $t < 0.1$  s) pressure spikes of up to 10 bar absolute are permitted. The service life of the shaft seal ring decreases with an increase in the frequency of pressure spikes.

The case pressure must be equal to or greater than the external pressure on the shaft seal ring.

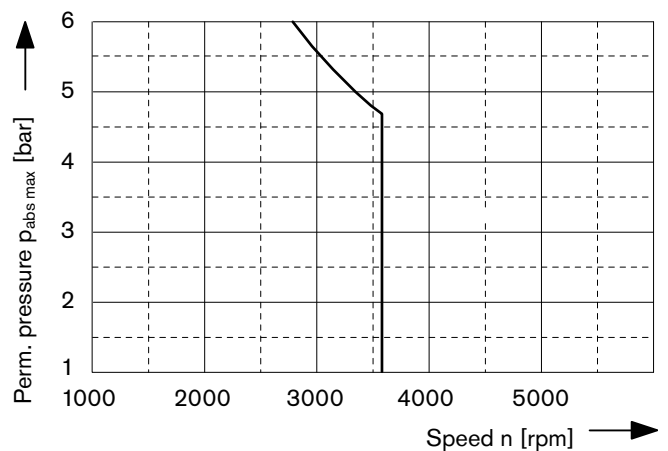

#### Temperature range

The FKM shaft seal ring may be used for case drain temperatures from -25 °C to +115 °C.

#### Note

For application cases below -25 °C, an NBR shaft seal ring is necessary (permissible temperature range: -40 °C to +90 °C). State NBR shaft seal ring in plain text when ordering. Please contact us.

# Technical data

## Operating pressure range

### Pressure at service line port A or B

**Nominal pressure**  $p_{nom}$  \_\_\_\_\_ 300 bar absolute

**Maximum pressure**  $p_{max}$  \_\_\_\_\_ 350 bar absolute

Single operating period \_\_\_\_\_ 10 s

Total operating period \_\_\_\_\_ 300 h

**Minimum pressure (high-pressure side)** \_\_\_\_\_ 25 bar

**Minimum pressure (inlet)** \_\_\_\_\_ 10 bar  
(boost pressure setting must be higher depending on system)

**Rate of pressure change**  $R_{A\ max}$  \_\_\_\_\_ 9000 bar/s

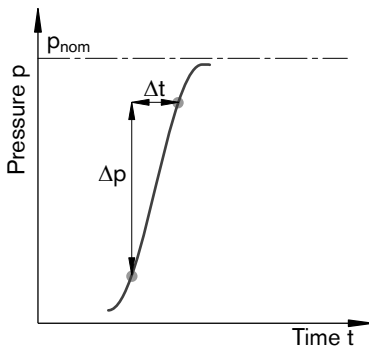

### Boost pump

#### Pressure at suction port S

Duration  $p_{S\ min}$  ( $v \leq 30\ mm^2/s$ ) \_\_\_\_\_  $\geq 0.8$  bar absolute

at cold starts, short-term ( $t < 3\ min$ ) \_\_\_\_\_  $\geq 0.5$  bar absolute

Maximum  $p_{S\ max}$  \_\_\_\_\_  $\leq 5$  bar absolute

**Nominal pressure**  $p_{Sp\ nom}$  \_\_\_\_\_ 25 bar

**Maximum pressure**  $p_{Sp\ max}$  \_\_\_\_\_ 40 bar

### Control pressure

To ensure the function of the control, the following control pressure is required depending on the speed and operating pressure (measurement point, port P<sub>S</sub>):

For controls EP and HW

Minimum control pressure  $p_{St\ min}$  (at  $n = 2000\ rpm$ ) \_\_\_\_\_ 20 bar

## Definition

### Nominal pressure $p_{nom}$

The nominal pressure corresponds to the maximum design pressure.

### Maximum pressure $p_{max}$

The maximum pressure corresponds to the maximum operating pressure within the single operating period. The sum of the single operating periods must not exceed the total operating period.

### Minimum pressure (high-pressure side)

Minimum pressure on the high-pressure side (A or B) that is required in order to prevent damage to the axial piston unit.

### Minimum pressure (inlet)

Minimum pressure in inlet (A or B) that is required in order to prevent damage to the axial piston unit.

### Rate of pressure change $R_A$

Maximum permissible rate of pressure build-up and pressure reduction during a pressure change over the entire pressure range.

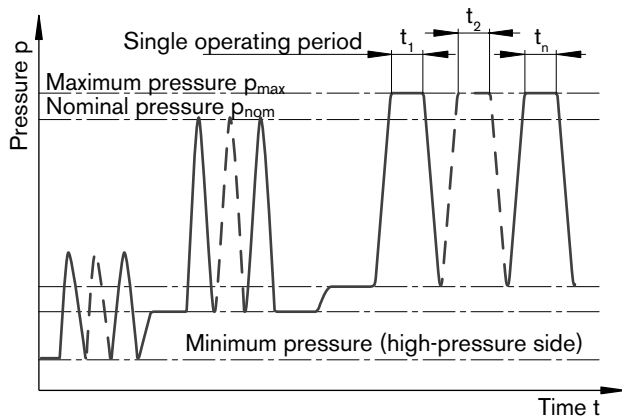

Total operating period =  $t_1 + t_2 + \dots + t_n$

# Technical data

**Table of values** (theoretical values, without efficiency and tolerances; values rounded)

Size	NG		28
Displacement			
variable pump for each circuit	$V_{g \max}$	cm <sup>3</sup>	28
boost pump (at p = 20 bar)	$V_{g \max}$	cm <sup>3</sup>	15.1
Speed			
at $V_{g \max}$	$n_{\text{nom}}$	rpm	3600
minimum	$n_{\text{min}}$	rpm	500
Flow for each circuit			
at $n_{\text{nom}}$ and $V_{g \max}$	$q_{v \max}$	l/min	101
Power <sup>1)</sup>			
at $n_{\text{nom}}$ , $V_{g \max}$ and $\Delta p = 300 \text{ bar}$	$P_{\max}$	kW	101
Torque <sup>1)</sup>			
at $V_{g \max}$ and $\Delta p = 300 \text{ bar}$	$T_{\max}$	Nm	267
at $V_{g \max}$ and $\Delta p = 100 \text{ bar}$	T	Nm	89
Rotary stiffness			
drive shaft S7	c	Nm/rad	89793
drive shaft V8	c	Nm/rad	91445
Moment of inertia for rotary group	$J_{GR}$	kgm <sup>2</sup>	0.0083
Maximum angular acceleration <sup>2)</sup>	$\alpha$	rad/s <sup>2</sup>	16660
Filling capacity	V	L	1.1
Mass approx. (without through drive)	m	kg	51.5

1) Without boost pump

2) The area of validity lies between the minimum required and maximum permissible speed.

It applies for external stimuli (e. g. engine 2 to 8 times rotary frequency, cardan shaft twice the rotary frequency).

The limit value applies for a single pump only.

The load capacity of the connection parts must be considered.

## Note

Operation above the maximum values or below the minimum values may result in a loss of function, a reduced service life or in the destruction of the axial piston unit. We recommend testing the loads by means of experiment or calculation / simulation and comparison with the permissible values.

## Determining the size

Flow	$q_v = \frac{V_g \cdot n \cdot \eta_v}{1000}$	[L/min]	$V_g$ = Displacement per revolution in cm <sup>3</sup>
			$\Delta p$ = Differential pressure in bar
Torque	$T = \frac{V_g \cdot \Delta p}{20 \cdot \pi \cdot \eta_{mh}}$	[Nm]	n = Speed in rpm
			$\eta_v$ = Volumetric efficiency
Power	$P = \frac{2 \pi \cdot T \cdot n}{60000} = \frac{q_v \cdot \Delta p}{600 \cdot \eta_t}$	[kW]	$\eta_{mh}$ = Mechanical-hydraulic efficiency
			$\eta_t$ = Total efficiency ( $\eta_t = \eta_v \cdot \eta_{mh}$ )

# Technical data

## Permissible radial and axial loading on drive shaft

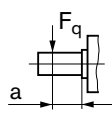
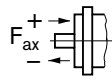
Size	NG		28	28	
Drive shaft		in	1 1/4	1 3/8	
Radial force maximum at distance a (from shaft collar)		$F_{q \max}$	N	4505	7000
		a	mm	24	24
Axial force maximum		$+ F_{ax \max}$	N	2910	2910
		$- F_{ax \max}$	N	1490	1490

### Note

Special requirements apply in the case of belt drives. Please contact us.

Force-transfer direction of the permissible axial force:

+  $F_{ax \max}$  = Increase in service life of bearings

-  $F_{ax \max}$  = Reduction in service life of bearings (avoid)

## Permissible input and through-drive torques

Size	NG		28		
Torque at $V_{g \max}$ and $\Delta p = 300 \text{ bar}^1$		$T_{\max}$	Nm	267	
Input torque at drive shaft, maximum <sup>2)</sup>					
	<b>S7</b>	1 1/4 in	$T_{E \max}$	Nm	602
	<b>V8</b>	1 3/8 in	$T_{E \max}$	Nm	970
Maximum through-drive torque		$T_{D \max}$	Nm	521	

1) Efficiency not considered

2) For drive shafts with no radial force

### Torque distribution

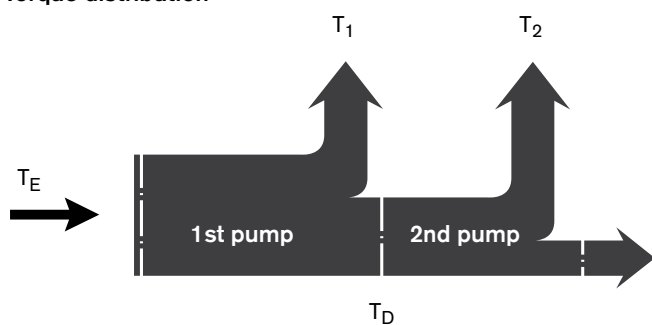



# HW – Proportional control hydraulic, mechanical servo

The output flow of the pump can be steplessly varied in the range between 0 to 100 %, proportional to the rotation of the control lever between 0° and ±29°.

A feedback lever connected to the stroke piston maintains the pump flow for any given position of the control lever between 0° and 29°.

If the pump is also equipped with a DA control valve (see page 11), automotive operation is possible for travel drives.

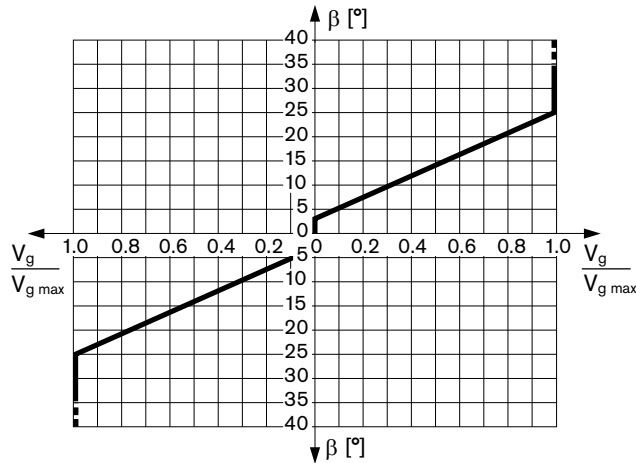

Swivel angle  $\beta$  at the control lever for deflection:

Start of control at  $\beta = 3^\circ$

End of control at  $\beta = 25^\circ$  (max. displacement  $V_{g\ max}$ )

Mechanical stop for  $\beta: \pm 40^\circ$

The maximum required torque at the lever is 170 Ncm. To prevent damage to the HW control unit, a positive mechanical stop must be provided for the HW control lever.

**Note**

Spring centering enables the pump, depending on pressure and speed, to move automatically to the neutral position ( $V_g = 0$ ) as soon as there is no longer any torque on the control lever of the HW control unit (regardless of deflection).

**Assignment**

Direction of rotation - Control - Flow direction				
Direction of rotation	Lever direction	Control pressure	Flow direction	Operating pressure
	cw	a	$X_2$	$B_1$ to $A_1$ $B_2$ to $A_2$
b		$X_1$	$A_1$ to $B_1$ $A_2$ to $B_2$	$M_{B1}$ $M_{B2}$
ccw	a	$X_2$	$A_1$ to $B_1$ $A_2$ to $B_2$	$M_{B1}$ $M_{B2}$
	b	$X_1$	$B_1$ to $A_1$ $B_2$ to $A_2$	$M_{A1}$ $M_{A2}$

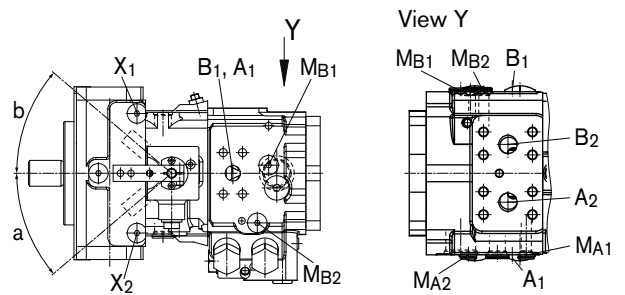

**Circuit diagram**

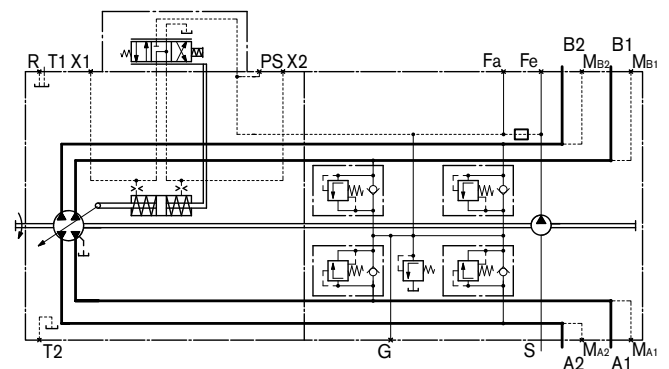

# EP – Proportional control electric

The output flow of the pump can be steplessly varied in the range between 0 to 100 %, proportional to the electrical current supplied to solenoid a or b.

The electrical energy is converted into a force acting on the control piston. This control piston then directs control hydraulic fluid into and out of the stroke cylinder to adjust pump displacement as required.

A feedback lever connected to the stroke piston maintains the pump flow for any given current within the control range.

If the pump is also equipped with a DA control valve (see page 11), automotive operation is possible for travel drives.

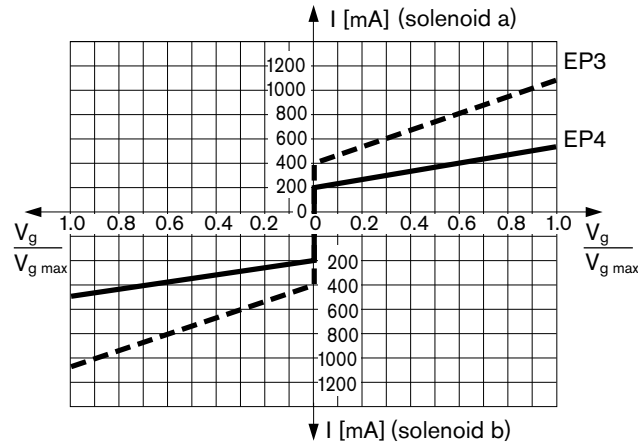

### Standard

Proportional solenoid without emergency actuation.

### On request

Proportional solenoid with emergency actuation and spring return.

Technical data, solenoid	EP3	EP4
Voltage	12 V (±20 %)	24 V (±20 %)
Start of control at $V_{g0}$	400 mA	200 mA
End of control at $V_{gmax}$	1090 mA	540 mA
Limiting current	1.54 A	0.77 A
Nominal resistance (at 20 °C)	5.5 Ω	22.7 Ω
Dither frequency	100 Hz	100 Hz
Actuated time	100 %	100 %

Type of protection see connector design page 11

The following electronic controllers and amplifiers are available for controlling the proportional solenoids:

- BODAS controller RC
  - Series 20 \_\_\_\_\_ RE 95200
  - Series 21 \_\_\_\_\_ RE 95201
  - Series 22 \_\_\_\_\_ RE 95202
  - Series 30 \_\_\_\_\_ RE 95203
 and application software
- Analog amplifier RA \_\_\_\_\_ RE 95230

Further information can also be found on the Internet at [www.boschrexroth.com/mobile-electronics](http://www.boschrexroth.com/mobile-electronics).

### Note

**The spring return feature in the control unit is not a safety device**

The spool valve inside the control unit can get stuck in an undefined position by internal contamination (contaminated hydraulic fluid, abrasion or residual contamination from system components). As a result, the axial piston unit can no longer supply the flow specified by the operator.

Check whether your application requires that remedial measures be taken on your machine in order to bring the driven consumer into a safe position (e. g. immediate stop).

### Assignment

Direction of rotation - Control - Flow direction				
	Actuation of solenoid	Control pressure	Flow direction	Operating pressure
Direction of rotation ccw	a	$X_1$	$A_1$ to $B_1$	$M_{B1}$
			$A_2$ to $B_2$	$M_{B2}$
	b	$X_2$	$B_1$ to $A_1$	$M_{A1}$
			$B_2$ to $A_2$	$M_{A2}$
Direction of rotation cw	a	$X_1$	$B_1$ to $A_1$	$M_{A1}$
			$B_2$ to $A_2$	$M_{A2}$
	b	$X_2$	$A_1$ to $B_1$	$M_{B1}$
			$A_2$ to $B_2$	$M_{B2}$

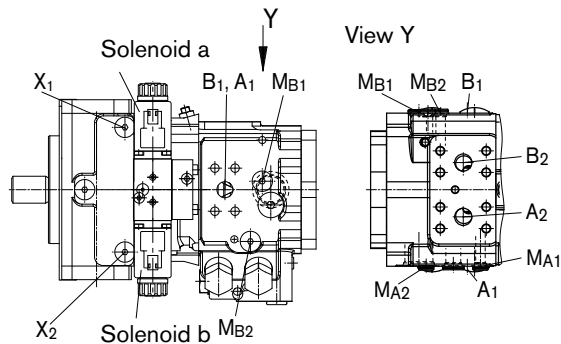

### Circuit diagram

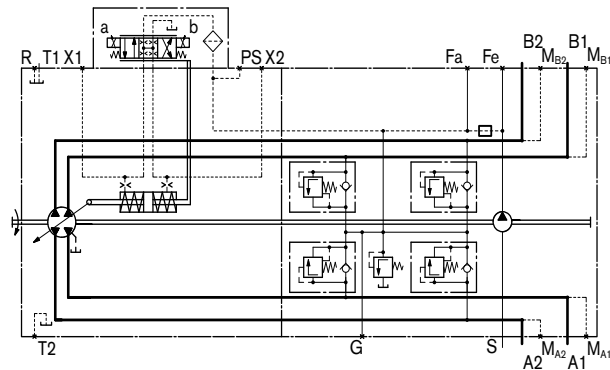

# Connector for solenoids

## DEUTSCH DT04-2P-EP04, 2-pin

Molded, without bidirectional suppressor diode \_\_\_\_\_ P

Type of protection according to DIN/EN 60529:  
IP67 and IP69K

### Circuit symbol

Without bidirectional suppressor diode

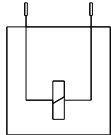

### Mating connector

DEUTSCH DT06-2S-EP04  
Rexroth Mat. No. R902601804

Consisting of: \_\_\_\_\_ DT designation  
 – 1 case \_\_\_\_\_ DT06-2S-EP04  
 – 1 wedge \_\_\_\_\_ W2S  
 – 2 female connectors \_\_\_\_\_ 0462-201-16141

The mating connector is not included in the delivery contents.  
This can be supplied by Rexroth on request.

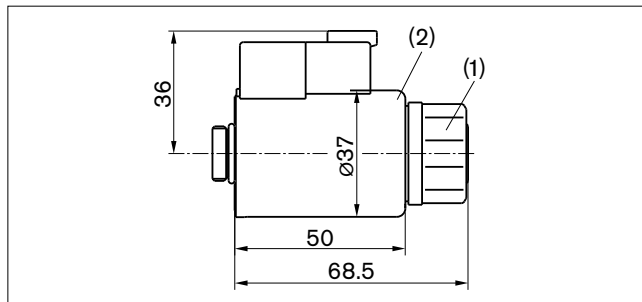

### Changing connector position

If necessary, you can change the position of the connector by turning the solenoid.

To do this, proceed as follows:

1. Loosen the fixing nut (1) of the solenoid. To do this, turn the fixing nut (1) one turn counter-clockwise.
2. Turn the solenoid body (2) to the desired position.
3. Retighten the fixing nut.  
Tightening torque of the fixing nut:  $5 \pm 1$  Nm  
(size SW 26, 12 kt DIN 3124).

On delivery, the position of the connector may differ from that shown in the brochure or drawing.

# DA control valve

## Fixed setting, speed related control pressure supply

The DA closed loop control is an engine speed-dependent system for travel drives. The built-in DA control valve generates a pilot pressure that is proportional to pump (engine) drive speed. This pilot pressure is directed to the stroke cylinder of the pump by an electromagnetically actuated 4/3-directional valve. The pump displacement can be steplessly varied in each flow direction and is influenced by both the speed of the pump drive and the system pressure. The flow direction (i. e. machine moving forward or backward) is determined by either solenoid a or b being activated.

Increasing the speed of the pump drive generates a higher pilot pressure by the DA control valve with the resulting flow and/or delivery pressure from the pump.

Depending on the selected operating characteristics of the pump, increasing the system pressure (i. e. machine load) will have the effect of swiveling the pump back to a smaller displacement. An overload protection circuit for the engine (against stalling) is achieved by combining this pressure-dependent reduction in pump stroke with a reduction in pilot pressure as the engine speed drops.

Any additional power requirement, e. g. hydraulic functions from attachments, could cause the speed of the engine to drop further. This will cause a further reduction in pilot pressure and thus of the pump displacement. Automatic power distribution and full exploitation of the available power are achieved in this way, both for the travel drive and for the implement hydraulics, with priority given to the implement hydraulics.

Various override options are available for DA control function to allow controlled operation of the implement hydraulics with high rpm at reduced vehicle speed.

The DA control valve can be used in pumps with EP and HW control units to protect the combustion engine against overload.

*DA closed loop control is only suitable for certain types of drive system and requires review of the engine and vehicle parameters to ensure that the pump is used correctly and that machine operation is safe and efficient. We recommend that all DA applications be reviewed by a Rexroth application engineer.*

### Standard

Switching solenoid without emergency actuation.

### On request

Switching solenoid with emergency actuation and spring return.

Technical data, solenoid	DA1	DA2
Voltage	12 V DC ( $\pm 20$ %)	24 V DC ( $\pm 20$ %)
Neutral position $V_{g0}$	de-energized	de-energized
Position $V_{gmax}$	current energized	current energized
Nominal resistance (at 20 °C)	5.5 $\Omega$	21.7 $\Omega$
Nominal power	26.2 W	26.5 W
Active current, minimum required	1.32 A	0.67 A
Actuated time	100 %	100 %
Type of protection see connector design page 11		

# Dimensions size 28

Before finalizing your design, request a binding installation drawing. Dimensions in mm.

## HW – Proportional control hydraulic, mechanical servo

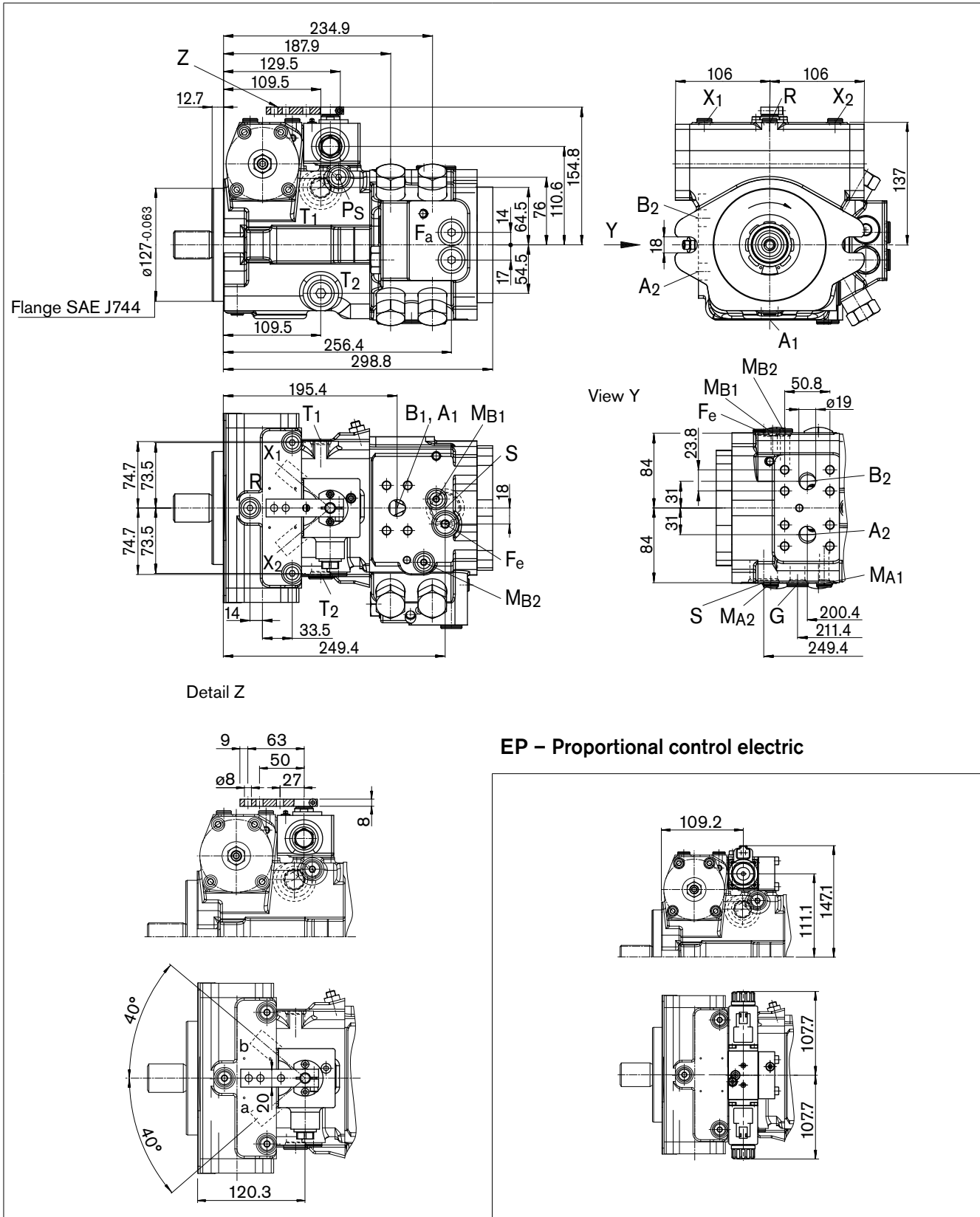

# Dimensions size 28

Before finalizing your design, request a binding installation drawing. Dimensions in mm.

## Drive shafts

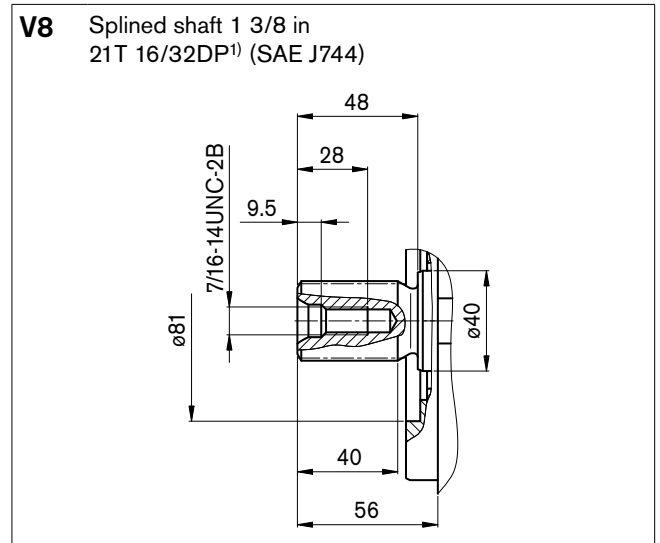
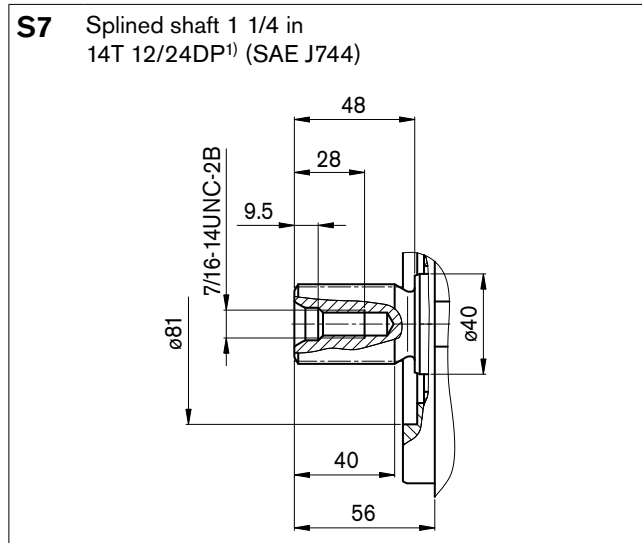

## Ports

Designation	Port for	Standard	Size <sup>2)</sup>	Maximum pressure [bar] <sup>3)</sup>	State
A, B	Service line	SAE J518 <sup>4)</sup>	3/4 in	350	O
	Fixing thread A/B	DIN 13	M10 x 1.5; 17 deep		O
S	Suction	ISO 6149	M33 x 2; 18 deep	5	O <sup>5)</sup>
T <sub>1</sub>	Tank	ISO 6149	M22 x 1.5; 14 deep	3	O <sup>6)</sup>
T <sub>2</sub>	Tank	ISO 6149	M22 x 1.5; 14 deep	3	X <sup>6)</sup>
R	Air bleed	ISO 6149	M12 x 1.5; 12 deep	3	X
X <sub>1</sub> , X <sub>2</sub>	Control pressure (upstream of orifice)	ISO 6149	M12 x 1.5; 12 deep	40	X
X <sub>3</sub> , X <sub>4</sub> <sup>7)</sup>	Stroking chamber pressure	ISO 6149	M12 x 1.5; 12 deep	40	X
G	Auxiliary pressure	ISO 6149	M18 x 1.5; 14.5 deep	40	X
P <sub>S</sub>	Control pressure supply	ISO 6149	M14 x 1.5; 13 deep	40	X
M <sub>A</sub> , M <sub>B</sub>	Measuring pressure A, B	ISO 6149	M12 x 1.5; 11,5 deep	350	X
F <sub>a</sub>	Filter outlet	ISO 6149	M18 x 1.5; 14.5 deep	40	X
F <sub>e</sub>	Filter inlet	ISO 6149	M18 x 1.5; 14.5 deep	40	X

1) ANSI B92.1a-1976, 30° pressure angle, flat root, side fit, tolerance class 5

2) Observe the general instructions on page 20 for the maximum tightening torques.

3) Short-term pressure spikes may occur depending on the application. Keep this in mind when selecting measuring devices and fittings.

4) Only dimensions according to SAE J518

5) Plugged for external supply

6) Depending on installation position, T1 or T2 must be connected (see also page 19).

7) Optional, see page 17

O = Must be connected (plugged on delivery)

X = Plugged (in normal operation)

# Through drive dimensions

Before finalizing your design, request a binding installation drawing. Dimensions in mm.

Flange SAE J744			Coupling for splined shaft <sup>1)</sup>		
Diameter	Mounting variant		Diameter	Designation	
	Symbol	Designation			
Without					<b>0000</b>
82-2 (A)	⌀	A1	5/8 in	9T 16/32DP S2	<b>A1S2</b>
	∞	A2	5/8 in	9T 16/32DP S2	<b>A2S2</b>
101-2 (B)	⌀	B1	7/8 in	13T 16/32DP S4	<b>B1S4</b>
			1 in	15T 16/32DP S5	<b>B1S5</b>
	∞	B2	7/8 in	13T 16/32DP S4	<b>B2S4</b>
			1 in	15T 16/32DP S5	<b>B2S5</b>

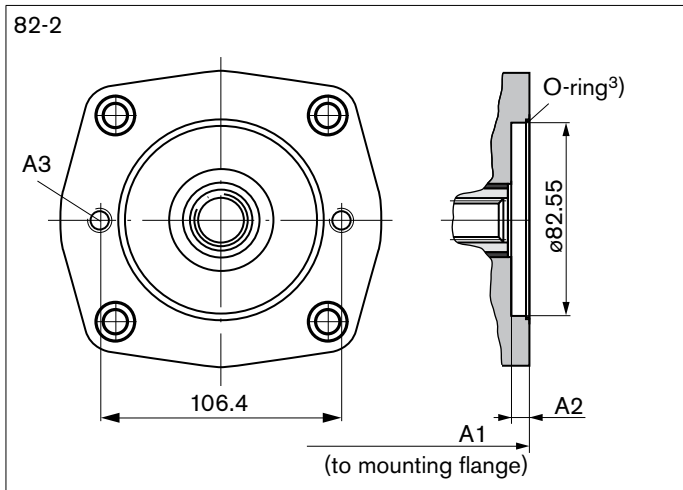

NG	A1	A2	A3 <sup>2)</sup>
28	302.8	9	M10 x 1.5; 17.5 deep

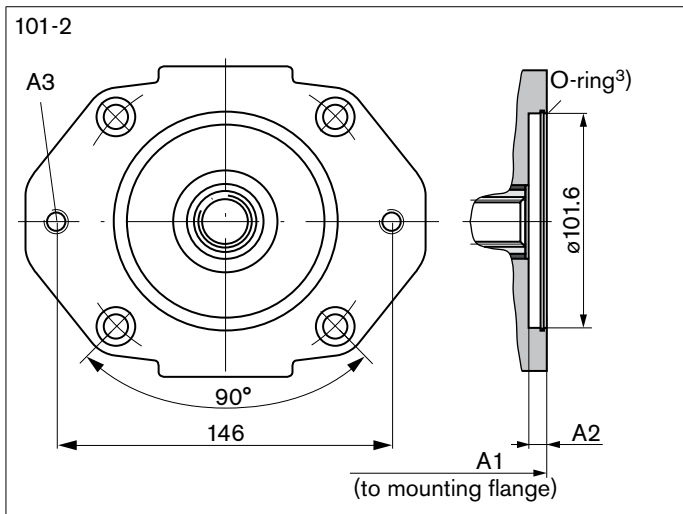

NG	A1	A2	A3 <sup>2)</sup>
28	303.8	10	M12 x 1.75; 18.5 deep

- 1) Coupling for splined shaft according to ANSI B92.1a-1976, 30° pressure angle, flat root, side fit, tolerance class 5
- 2) Thread according to DIN 13, observe the general instructions on page 20 for the maximum tightening torques.
- 3) O-ring included in the delivery contents

# Through drive dimensions

Before finalizing your design, request a binding installation drawing. Dimensions in mm.

Flange SAE J744			Coupling for splined shaft <sup>1)</sup>		
	Mounting variant				
Diameter	Symbol	Designation	Diameter	Designation	
127-2 (C)	∞	C2	1 1/4 in	14T 12/24DP	S7
					<b>C2S7</b>

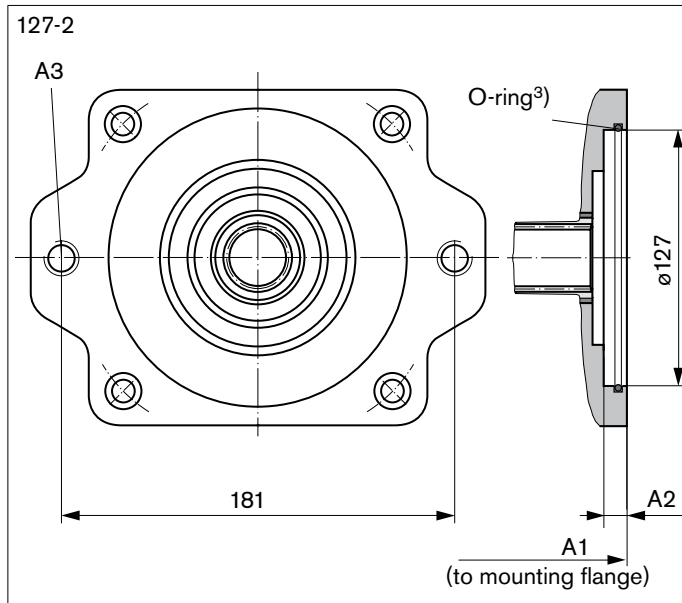

NG	A1	A2	A3 <sup>2)</sup>
28	310.1	14	M16 x 2; 24.8 deep

**Note**

For the mounting of a pump at the through drive, a pump support is recommended. Please contact us.

- 1) Coupling for splined shaft according to ANSI B92.1a-1976, 30° pressure angle, flat root, side fit, tolerance class 5
- 2) Thread according to DIN 13, observe the general instructions on page 20 for the maximum tightening torques.
- 3) O-ring included in the delivery contents

## Overview of attachments

Through drive			Attachment for 2nd pump						
Flange	Coupling for splined shaft	Short code	A4VG/32 NG (shaft)	A10VG NG (shaft)	A10V(S)O/31 NG (shaft)	A10V(S)O/53 NG (shaft)	A4FO NG (shaft)	A11VO NG (shaft)	External gear pump
82-2 (A)	5/8 in	A_S2	–	–	18 (U)	10 (U)	–	–	Size F NG4 to 22 <sup>1)</sup>
101-2 (B)	7/8 in	B_S4	–	18 (S)	28 (S, R)	28 (S,R)	16 (S), 22 (S)	–	Size N NG20 to 32 <sup>1)</sup>
					45 (U)	45 (U,W)	28 (S)	Size G NG38 to 45 <sup>1)</sup>	
	1 in	B_S5	28 (S)	28 (S), 45 (S)	45 (S,R)	45 (S,R) 60 (U,W)	–	40 (S)	–
127-2 (C)	1 1/4 in	C_S7	40 (S), 56 (S), 71 (S)	63 (S)	71 (S, R) 100 (U)	85 (U)	–	60 (S)	–

1) Rexroth recommends special versions of the gear pumps. Please contact us.

# High-pressure relief valves

Before finalizing your design, request a binding installation drawing. Dimensions in mm.

The two high-pressure relief valves protect the hydrostatic transmission (pump and motor) from overload. They limit the maximum pressure in the respective high-pressure line and serve simultaneously as boost valves.

Standard setting  $\Delta p_{HD}$  \_\_\_\_\_ 280 bar

For other pressure settings in the  $p_{abs} = 250$  to 330 bar range, please contact us.

## Setting diagram

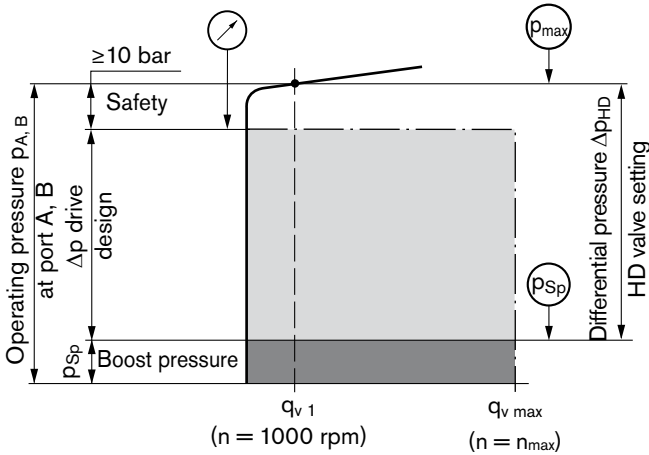

### Note

The valve settings are made at  $n = 1000$  rpm and at  $V_{gmax}$  ( $q_{v1}$ ). There may be deviations in the opening pressures with other operating parameters.

For reasons of simplification, the bypass function is not shown in these circuit diagrams.

## Installation situation for coupling assembly

To ensure that rotating components (coupling hub) and fixed components (case, retaining ring) do not come into contact with each other, the installation conditions described here must be observed. This depends on the size and the splined shaft.

**SAE splined shaft** (spline according to ANSI B92.1a-1976)

The outer diameter of the coupling hub must be smaller than the inner diameter of the retaining ring  $d_2$  in the area near the drive shaft collar (dimension  $x_2 - x_3$ ).

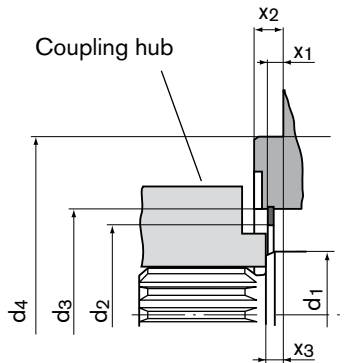

NG	Mounting flange	$\text{ø}d_1$	$\text{ø}d_{2 \text{ min}}$	$\text{ø}d_3$	$\text{ø}d_4$	$x_1$	$x_2$	$x_3$
28	127-2 (C)	40	54.4	$68 \pm 0.1$	127	$7.0^{+0.2}$	$12.7_{-0.5}$	$8^{+0.9}_{-0.6}$



# Mechanical stroke limiter

The mechanical stroke limiter is an auxiliary function allowing the maximum displacement of the pump to be steplessly reduced, regardless of the control unit used.

The stroke of the stroke cylinder and hence the maximum swivel angle of the pump are limited by means of two adjusting screws.

### Dimensions

NG	M1	M2	M3
28	130.5 maximum	44	25.5

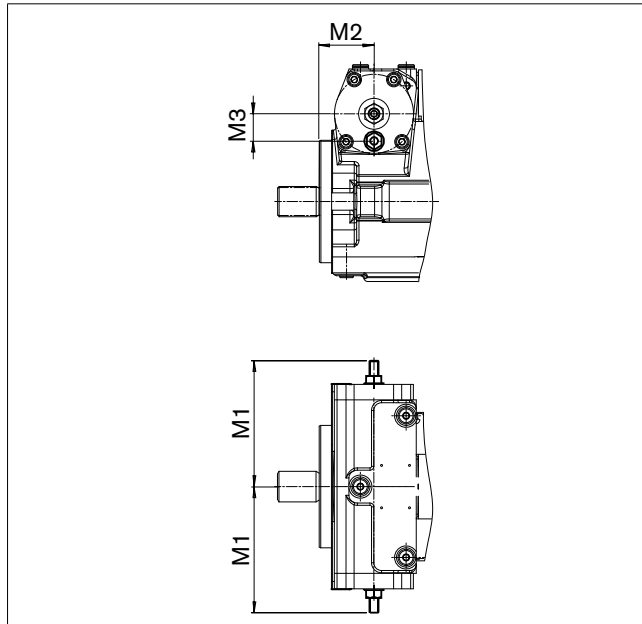

### Circuit diagram

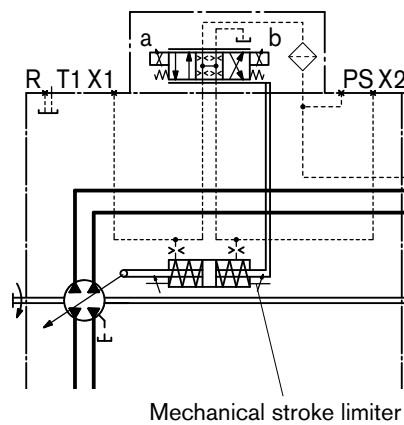

# Ports X<sub>3</sub> and X<sub>4</sub> for stroking chamber pressure

### Dimensions

NG	T1	T2	T4
28	104.5	44	25

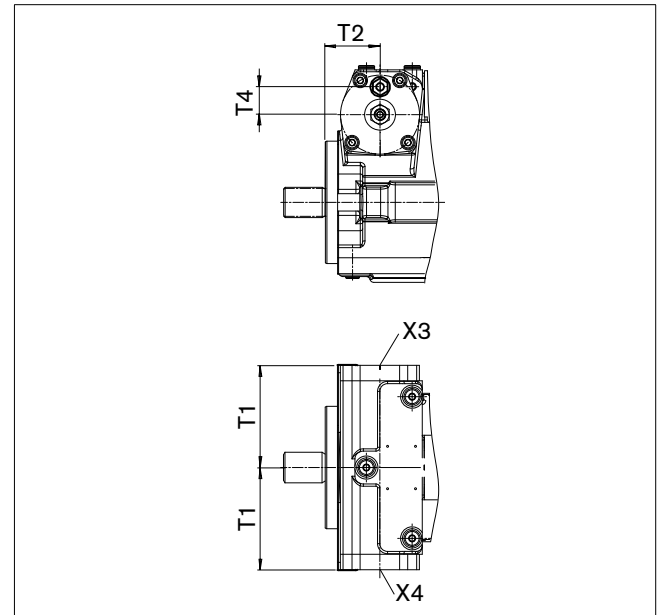

### Circuit diagram

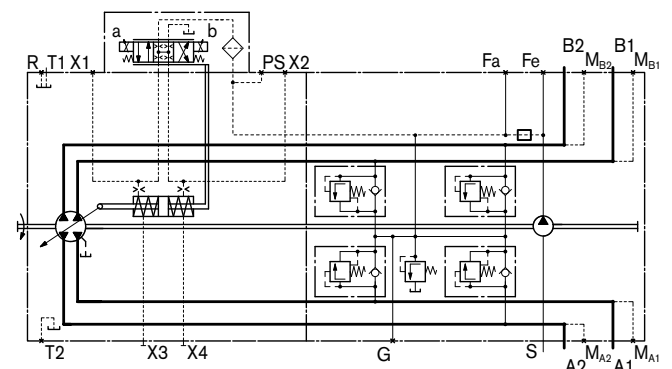

Designation	Port for	Standard	Size <sup>1)</sup>	Maximum pressure [bar] <sup>2)</sup>	State
X <sub>3</sub> , X <sub>4</sub>	Stroking chamber pressure	ISO 6149	M12 x 1.5; 12 deep	40	X

1) Observe the general instructions on page 20 for the maximum tightening torques.

2) Short-term pressure spikes may occur depending on the application. Keep this in mind when selecting measuring devices and fittings.

Before finalizing your design, request a binding installation drawing. Dimensions in mm.

# Filtration boost circuit / external supply

## Version S (standard)

### Filtration in the suction line of the boost pump

Standard version (preferred)

Filter type \_\_\_\_\_ filter **without** bypass

Recommendation \_\_\_\_\_ **with** contamination indicator

Flow resistance at filter cartridge

With  $v = 30 \text{ mm}^2/\text{s}$ ,  $n = n_{\text{max}}$  \_\_\_\_\_  $\Delta p \leq 0.1 \text{ bar}$

With  $v = 1000 \text{ mm}^2/\text{s}$ ,  $n = n_{\text{max}}$  \_\_\_\_\_  $\Delta p \leq 0.3 \text{ bar}$

Pressure at port S of the boost pump

Suction pressure  $p_{S \text{ min}}$  ( $v \leq 30 \text{ mm}^2/\text{s}$ ) \_\_\_\_\_  $\geq 0.8 \text{ bar absolute}$

At cold start, short-term ( $t < 3 \text{ min}$ ) \_\_\_\_\_  $\geq 0.5 \text{ bar absolute}$

Suction pressure  $p_{S \text{ max}}$  \_\_\_\_\_  $\leq 5 \text{ bar absolute}$

The filter is not included in the delivery contents.

### Circuit diagram - standard version S

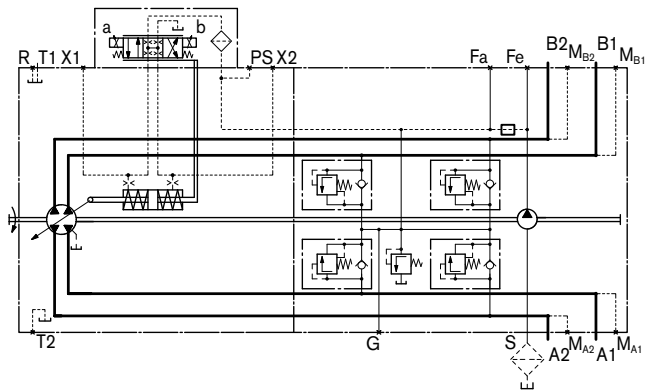

## Version E

### External supply

This variation should be used in versions **without** integrated boost pump (U).

Port S is plugged.

Supply comes from port  $F_a$ .

Filter arrangement \_\_\_\_\_ separate

To ensure the functional reliability, maintain the required cleanliness level for the boost pressure fluid fed in at port  $F_a$  (see page 5).

### Circuit diagram - version E

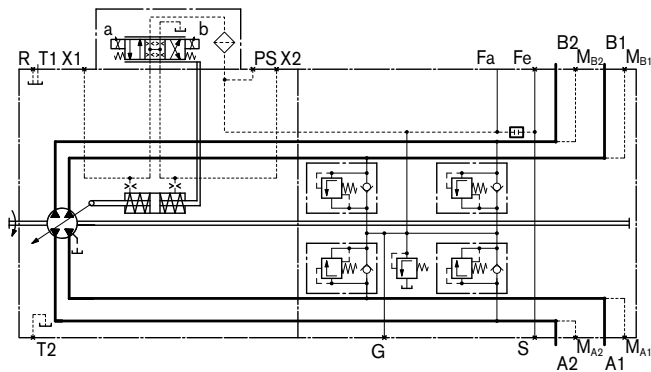

## Version D

### Filtration in the pressure line of the boost pump, ports for external boost circuit filter

Filter inlet \_\_\_\_\_ port  $F_e$

Filter outlet: \_\_\_\_\_ port  $F_a$

Filter type \_\_\_\_\_

Filters with bypass are **not recommended**. For applications with bypass please contact us.

Recommendation \_\_\_\_\_ **with** contamination indicator

Flow resistance at filter cartridge

With  $v = 30 \text{ mm}^2/\text{s}$  \_\_\_\_\_  $\Delta p \leq 1 \text{ bar}$

On cold start \_\_\_\_\_  $\Delta p \leq 3 \text{ bar}$

(valid for entire speed range  $n_{\text{min}} - n_{\text{max}}$ )

The filter is not included in the delivery contents.

### Circuit diagram - version D

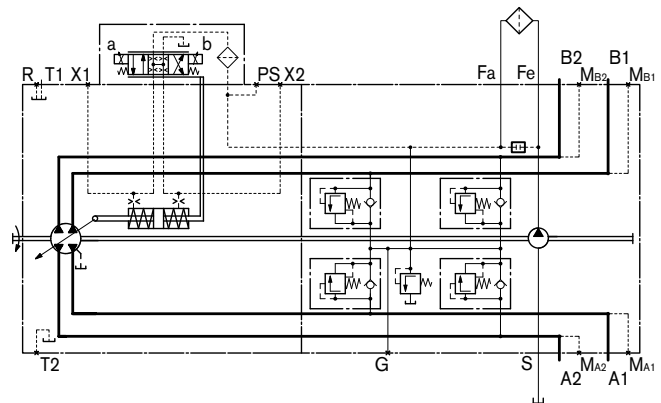

# Installation instructions

## General

During commissioning and operation, the axial piston unit must be filled with hydraulic fluid and air bled. This is also to be observed following a relatively long standstill as the system may empty via the hydraulic lines.

The case drain fluid in the case interior must be directed to the tank via the highest tank port ( $T_1$ ,  $T_2$ ). The minimum suction pressure at port S must not fall below 0.8 bar absolute (cold start 0.5 bar absolute).

In all operational states, the suction line and tank line must flow into the tank below the minimum fluid level.

## Installation position

See examples below. Additional installation positions are available upon request.

Recommended installation positions: 1 and 2.

### Below-tank installation (standard)

Pump below minimum fluid level of the tank.

### Above-tank installation

Pump above minimum fluid level of the tank

Observe the maximum permissible suction height  $h_{S\ max} = 800\ mm$ .

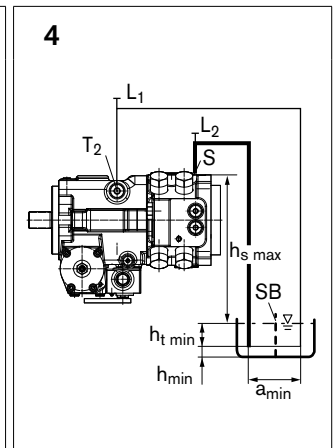
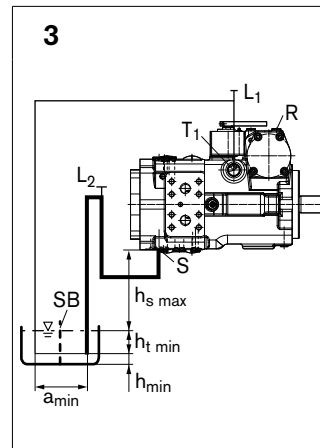
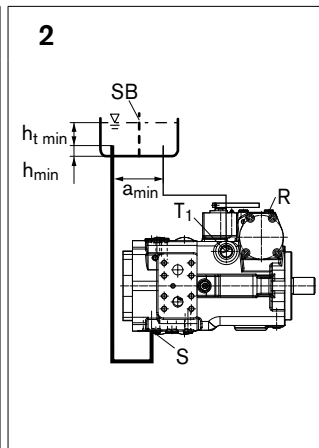
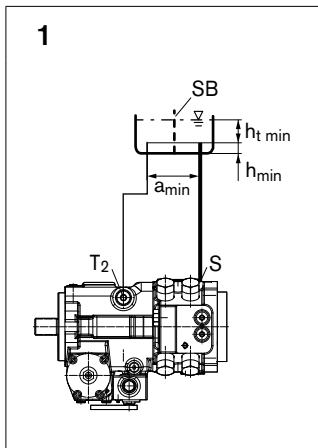

$h_{S\ max} = 800\ mm$ ,  $h_{t\ min} = 200\ mm$ ,  $h_{min} = 100\ mm$ , SB = baffle (baffle plate)

When designing the tank, ensure adequate distance  $a_{min}$  between the suction line and the case drain line to prevent the heated, return flow from being drawn directly back into the suction line.

Installation position	Air bleed	Filling
1	-	S + $T_2$
2	R	S + $T_1$

Installation position	Air bleed	Filling
3	$L_2 + R$	$L_1 + L_2$
4	$L_2 (S) + L_1 (T_2)$	$L_2 (S) + L_1 (T_2)$

# General instructions

- The A30VG pump is designed to be used in closed circuit.
- Project planning, assembly and commissioning of the axial piston unit require the involvement of qualified personnel.
- The service line ports and function ports are only designed to accommodate hydraulic lines.
- During and shortly after operation, there is a risk of burns on the axial piston unit and especially on the solenoids. Take appropriate safety measures (e. g. by wearing protective clothing).
- Depending on the operational state of the axial piston unit (operating pressure, fluid temperature), the characteristic may shift.
- Pressure ports:  
The ports and fixing threads are designed for the specified maximum pressure. The machine or system manufacturer must ensure that the connecting elements and lines correspond to the specified operating conditions (pressure, flow, hydraulic fluid, temperature) with the necessary safety factors.
- The data and notes contained herein must be adhered to.
- The following tightening torques apply:
  - Threaded hole for axial piston unit:  
The maximum permissible tightening torques  $M_{G \max}$  are maximum values for the threaded holes and must not be exceeded. For values, see the following table.
  - Fittings:  
Observe the manufacturer's instruction regarding the tightening torques of the used fittings.
  - Fixing screws:  
For fixing screws according to DIN 13, we recommend checking the tightening torque individually according to VDI 2230.
  - Locking screws:  
For the metal locking screws supplied with the axial piston unit, the required tightening torques of locking screws  $M_V$  apply. For values, see to the following table.
- The product is not approved as a component for the safety concept of a general machine according to DIN EN ISO 13849.

Threaded port sizes		Maximum permissible tightening torque of the threaded holes $M_{G \max}$	Required tightening torque of the locking screws $M_V$	WAF hexagon socket of the locking screws
M10 x 1.5	ISO 6149	30 Nm	20 Nm	5 mm
M12 x 1.5	ISO 6149	50 Nm	35 Nm	6 mm
M14 x 1.5	ISO 6149	80 Nm	45 Nm	6 mm
M18 x 1.5	ISO 6149	140 Nm	70 Nm	8 mm
M22 x 1.5	ISO 6149	210 Nm	100 Nm	10 mm
M33 x 2	ISO 6149	540 Nm	310 Nm	17 mm <sup>1)</sup>

1) Different from ISO 6149